

DC-Micromotors

3 mNm

Precious Metal Commutation

For combination with (overview on page 14-15)

Gearheads:
20/1, 22E, 22/2, 22/5, 22/6, 23/1, 38/3

Encoders:
5500, 5540

DC-Motor-Tacho Combinations:
2251 ... S

Series 2233 ... S

	2233 T	4,5 S	006 S	012 S	018 S	024 S	030 S	
1 Nominal voltage	U_N	4,5	6	12	18	24	30	Volt
2 Terminal resistance	R	1,3	2,9	9,7	25,0	57,0	105	Ω
3 Output power	$P_{2 \max.}$	3,85	3,06	3,66	3,18	2,47	2,08	W
4 Efficiency	$\eta_{\max.}$	86	85	84	82	80	79	%
5 No-load speed	n_0	8 000	8 000	8 500	8 700	8 800	9 300	rpm
6 No-load current (with shaft \varnothing 1,5 mm)	I_0	0,020	0,013	0,009	0,007	0,005	0,004	A
7 Stall torque	M_H	18,40	14,60	16,40	13,90	10,70	8,56	mNm
8 Friction torque	M_{fr}	0,11	0,09	0,12	0,14	0,13	0,12	mNm
9 Speed constant	k_n	1 790	1 340	714	488	371	314	rpm/V
10 Back-EMF constant	k_E	0,559	0,745	1,400	2,050	2,690	3,180	mV/rpm
11 Torque constant	k_M	5,34	7,12	13,40	19,60	25,70	30,40	mNm/A
12 Current constant	k_i	0,187	0,141	0,075	0,051	0,039	0,033	A/mNm
13 Slope of n-M curve	$\Delta n/\Delta M$	435	548	518	626	822	1 090	rpm/mNm
14 Rotor inductance	L	70	130	400	600	1 600	2 200	μH
15 Mechanical time constant	τ_m	12	11	12	14	11	12	ms
16 Rotor inertia	J	2,60	1,90	2,20	2,10	1,30	1,10	gcm ²
17 Angular acceleration	$\alpha_{\max.}$	70	76	74	65	84	81	$\cdot 10^3 \text{rad/s}^2$
18 Thermal resistance	R_{th1} / R_{th2}	4 / 27						K/W
19 Thermal time constant	τ_{w1} / τ_{w2}	4 / 660						s
20 Operating temperature range:								
- motor		- 30 ... + 85 (optional - 55 ... + 125)						$^{\circ}C$
- rotor, max. permissible		+ 125						$^{\circ}C$
21 Shaft bearings		sintered bronze sleeves		ball bearings		ball bearings, preloaded		
22 Shaft load max.:		(standard)		(optional)		(optional)		
- with shaft diameter		1,5		2,0		2,0		mm
- radial at 3 000 rpm (3 mm from bearing)		1,2		8		8		N
- axial at 3 000 rpm		0,2		0,8		0,8		N
- axial at standstill		20		10		10		N
23 Shaft play:								
- radial	\leq	0,03		0,015		0,015		mm
- axial	\leq	0,2		0,2		0		mm
24 Housing material		steel, zinc galvanized and passivated						
25 Weight		61						g
26 Direction of rotation		clockwise, viewed from the front face						

Recommended values - mathematically independent of each other

27 Speed up to	$n_{e \max.}$	8 000	8 000	8 000	8 000	8 000	8 000	rpm
28 Torque up to	$M_{e \max.}$	3	3	3	3	3	3	mNm
29 Current up to (thermal limits)	$I_{e \max.}$	1,340	0,900	0,490	0,300	0,200	0,140	A

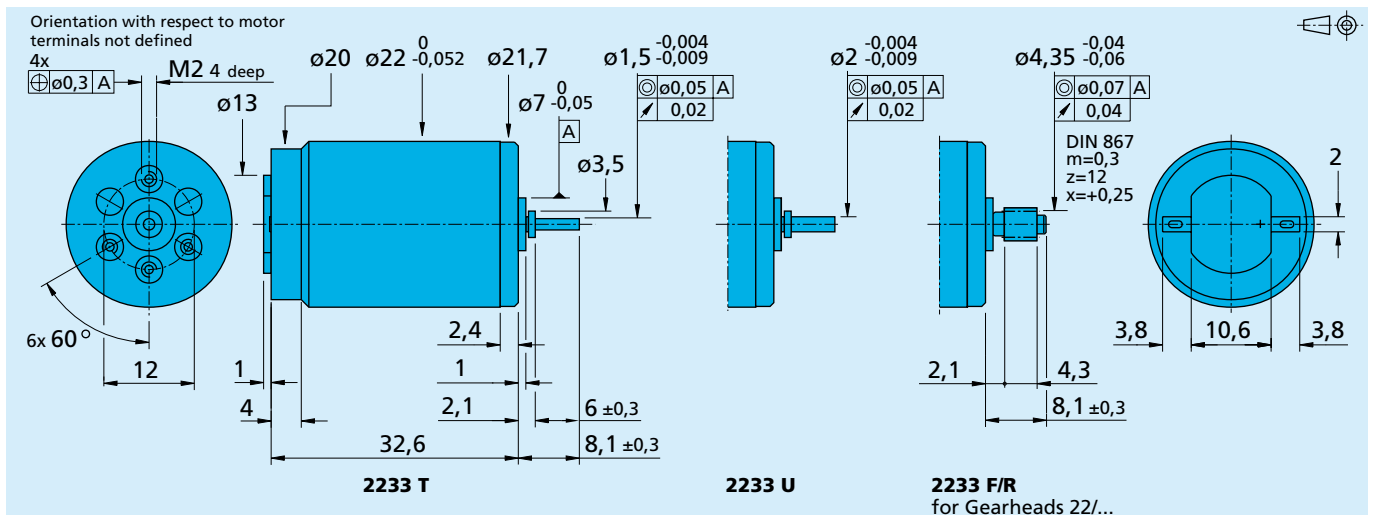

For details on technical information and lifetime performance refer to pages 28-34.

Edition 2006-2007

For options on DC-Micromotors refer to page 64. Specifications subject to change without notice.

www.faulhaber.com